

Design and implementation of new glass CNC sand blasting engraving machine and information system¹

WENLI YANG², YUCHUN ZHU², XIANGHUI LU²

Abstract. With the gradual improvement of people's living standards, the demand for stone handicrafts tends to rise. Glass, stone and other carved handicrafts have formed an important industry. At present, the degree of engraving automation in our country is generally low, and the traditional engraving processing technology has the problems of high energy consumption and high labor intensity. Therefore, the demand for new glass CNC sand blasting engraving machine is more and more intense. Drawing on the advanced processing ideas and methods at home and abroad, a new type of glass CNC sand blasting and engraving machine with higher intelligence was designed in this paper. Combined with the idea of CAD intelligent processing, the 3D model of glass and stone was constructed, and finally the process of robot machining integration was realized.

Key words. CNC engraving machine, information system, stone carving.

1. Introduction

Carving process is to remove and correct the surface of the carved material, and to make it a handicraft with a sense of space and three-dimensional beauty. This craft requires a natural or mission image that can be touched and perceived [1]. According to the morphological classification, sculpture can be divided into emboss, model sculpture and image sculpture. The living standard of people is undergoing great changes. People's pursuit of cultural life is not just a simple entertainment, but a deeper appreciation of art [2]. According to the basic requirements of artistic features and ornamental features, the sculpture industry, such as glass and stone, is rising quietly in recent years. The homogeneity of traditional sculpture craft in our country is higher, and the possibility of higher value added is not very high. Therefore, the

¹In this paper, high technology to transform Hebei province 2017 key research projects and promote the traditional industry "special glass Intelligent NC spraying carving technology research and application": 17211810D.

²Hebei Construction Material Vocational and Technical College, Qinhuangdao, Hebei, China, 066000

development of new products is slow [3]. The quality of traditional engraving is entirely dependent on the experience and craftsmanship of the master. If the number of craftsmen who train the craftsman spirit is constantly decreasing, the carving process will be confronted with the shortage of technicians [4]. Glass, stone and other arts and crafts urgently need a higher degree of automation equipment to solve the problem of engraving technology and technical personnel shortage. Therefore, the significance of this study lies in this.

2. State of the art

Glass and stone have many steps during the engraving process. Even for the companies that carry out the process are very mature, they rely heavily on manual work to do the necessary work processes. In particular, the basic carving of the crafts with complex shape is completed by hand [5]. Although the processing equipment of complex structures made in China has been applied in many fields, there is no CNC machining which can realize intelligent processing [6]. The main research results are also concentrated in the design phase of small CNC engraving machines. In foreign countries, the research on the engraving equipment for stone, glass and other crafts has entered a relatively mature stage. Industrial CCNC machine tools have been able to realize automatic integration of robots and machines [7]. The latest research results show that foreign CNC engraving machine has been able to automatically change tools, and automatically form cutting path. But the disadvantage is that equipment is expensive and manufacturing technology is basically blocked [8].

Industrial robots are widely used in industrial automation production process. They include advanced manufacturing technologies such as machinery, electronics, computers and artificial intelligence [9]. Since the design and manufacture of the first industrial robot, the robot has been bursting with great potential. Since 1970s, industrial robot technology has been developed rapidly. Many countries began to pay attention to the future development of industrial robots, and constantly put in a lot of manpower and material resources [10]. At present, CNC machine and industrial robots have been widely used in the field of automobile manufacturing and aerospace, and later developed into food processing, timber and furniture industries. The adoption of CCNC machine technology and intelligent robot manufacturing ideas into glass, stone and other crafts sculpture manufacturing will give full play to the multi axis flexibility of CNC machines and industrial robots to meet the processing requirements for the maximum space range and the special structure.

2.1. Methodology

Based on computer aided technology, a whole set of new glass numerical control sand blasting engraving machine system is designed. The system makes rough machining and finishing of glass, stone and other materials. Fig.1 shows the scheme design of engraving system. The whole CNC engraving system is divided into the mechanical structure part, the electrical control part, the modulation part, the displacement machine design, and the processing tool movement track. Besides the

design of robot body, the design and application of displacement machine is also an important structure of engraving machine system. The positioner is the special robot auxiliary equipment. It is more suitable for the rotary machining of materials with complicated structure, which can obtain ideal engraving and machining positions. The positioner, the operating machine and the electric welding machine are fully matched and used. They are connected with the welding machine system to realize the linkage operation. The positioner is applied to CNC engraving system, which can realize multi-directional machining and effectively handle machining dead angle. The use of positioner is mainly supported by the manufacturers of robots for sale, and the core manufacturing technology is also the manufacturer's business secrets. In this study, the application principle of positioner has broken through the manufacturing technology of CNC engraving machine.

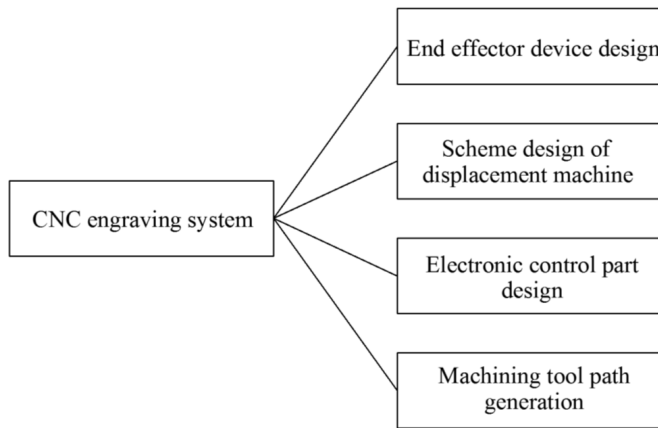

Fig. 1. Scheme design of engraving system

Fig. 2 shows the machining process of CNC engraving machine. The whole CNC engraving process is as follows. 3D modeling software UG and Solidworks are used for three-dimensional modeling design of the sculpture image. Then, the modeling image is imported into the CAM computer aided program to generate the reasonable running track of the CNC machining tool. The CNC machine tool is used to track the tool path according to the machining trajectory. Before optimizing the tool path, it is necessary to predict the possible machining problems in the process of machining and eliminate the interference that may exist in the process of tool movement. After obtaining the processing program of CNC engraving machine, it is embedded in the controller to do engraving. According to the reports, the correlation between cutting speed and cutting stress in stone and glass processing is relatively high. The feed speed and the change of cutting depth have a great influence on the cutting stress. Overall, however, the cutting depth has the greatest impact on the cutting force of the tool path.

The reason is that after increasing the feed rate, the arc area of cutting has no change in length direction, but only increases the maximum cutting thickness and normal contact stress. Therefore, in the phase of the efficiency of utilization

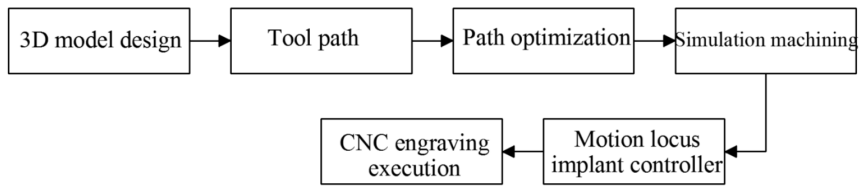

Fig. 2. Machining process of CNC engraving machine

involves cutting tools, it is better to increase the cutting speed and minimize the cutting depth in the allowable range of CNC machine tools, so as to minimize the material damage caused by cutting stress. The speed of cutting is closely related to the surface quality of the stone. Therefore, the high-speed motor is selected in this paper, which can improve the cutting rate of the tool better, and then improve the quality of the surface material of the stone [11].

Power driven cutting tools can process materials. The power unit is an important part of the structure. Therefore, when it comes to this part of the component, the appropriate engraving machine power device should be chosen. The end effector should have the basic functions of driving tools, and choose different cutters according to different machining conditions. Because of the material difference of cutting, the speed of engraving tool is different, and the maximum speed can reach 10000 rpm /min. During the general carbide processing, cutting process requires a fast tool's rotate speed. The main driving force is the speed control function of the power unit, which meets the requirements of machining performance. The two stages of finishing and roughing require different tool properties. The machine tools with higher degree of automation can replace the manual suspension of tool change. It is considered that the replacement of cutting tools is not only inefficient, but also has great security risks [12].

Motor spindle is a new technology for CNC machine, and the main purpose is to effectively combine the spindle and motor. The motor spindle is widely used. The motor spindle with high rotating speed can replace the traditional gear box. During the operation, the vibration is small, the noise is relatively low, and the response rate is relatively fast [13]. Considering the drive requirements of the motor spindle, the main spindle of the motor should be lightweight and the speed change function should be fine. It can satisfy the function of the automatic replacement tool. Therefore, it is believed that the power unit of CNC sand blasting engraving machine is the main shaft of the motor. The selection of motor spindle combines the main process and parameters of cutting to calculate the cutting stress and the steering torque. The type of motor spindle is selected by power and tool interface parameters. In this paper, 120TD18Z5.5A motor spindle is selected by calculation. The maximum rotating speed of the shaft is 1820 rpm, and the rated power during operation is about 5.6 kW. Loose and tightened sensors are installed to meet the requirements of material engraving of different structures. The $U - f$ curve of the motor spindle is shown in Fig. 3.

The electronic control system needs to satisfy the communication, emergency

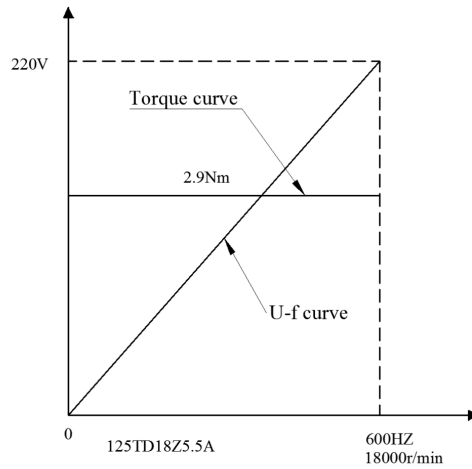

Fig. 3. $U - f$ curve of main shaft of CNC engraving machine

stop or open, I/O port allocation and other control functions, in which the I/O port allocation is affected by the control of the displacement machine. The controller of engraving machine can be selected as the central controller component of different material carving system, and the technical actions in the process are completed by the intelligent controller. The intelligent controller passes the machine information through the I/O and the outside. With the addition of the port of the SDI input signal of the link and the SDO output port, the feedback of signal reception and release is completed through the input and output ports. The output signal wiring diagram is depicted in Fig. 4.

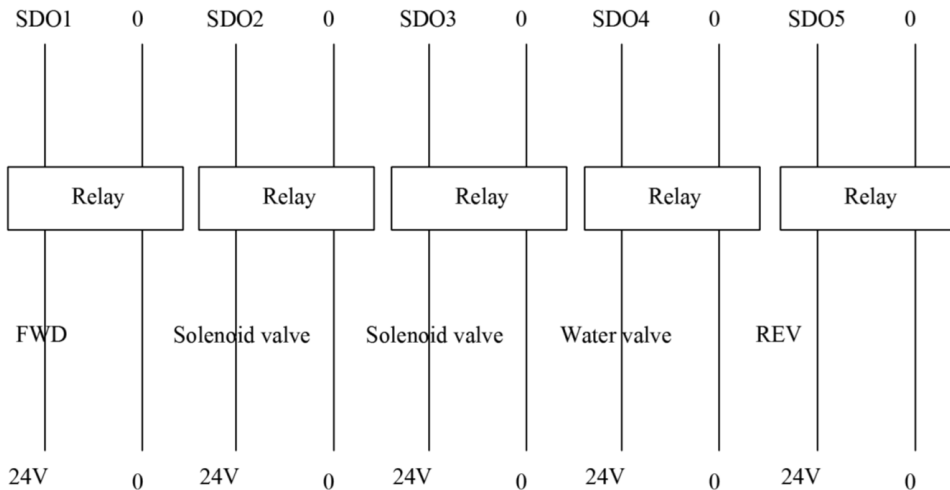

Fig. 4. Output signal wiring diagram

The design of control cabinet for CNC sand blasting and engraving system needs

to be analyzed and designed according to the function of system components. The inverter in the control cabinet has heat to emit at work. The components need to reserve a certain gap around. The heat dissipation part needs to be designed larger, so as to reserve the basic space for heat dissipation. The frequency conversion design is shown in Fig. 5. At the same time, the cooling part of the control cabinet needs to be designed with a cooling fan with higher power. A fan hole is designed and installed nearby the fan, which is equipped with warning, lifting and so on.

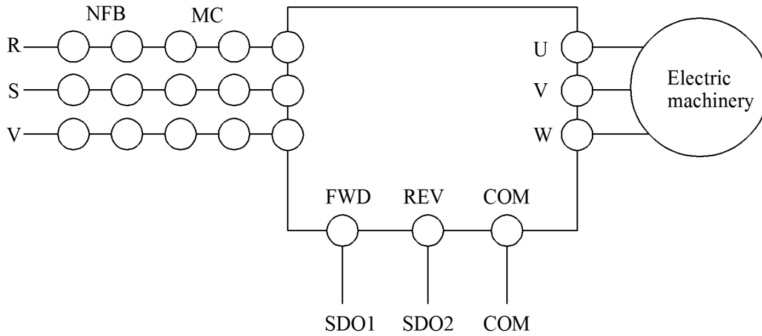

Fig. 5. Frequency converter wiring diagram

The design of mechanical structure mainly includes the grip design of motor spindle, the design and manufacture of the fixed platform, the choice of the tool and so on. The main shaft of the motor is connected with the machine control device by means of a grip. If the cutting speed is too high, the vibration will lead to the reduction of cutting accuracy. Choosing the right material and grip can reduce the weight and minimize the weight load of the CNC machine. Processing materials are generally heavy in weight. Therefore, in order to ensure the accuracy of cutting, it is necessary to use a relatively stable processing platform as a guarantee, and design reasonable processing fixed platform through a certain calculation. The tool has a great impact on the effect of CNC bed's processing and quality. Engraving machine cannot be separated from the use of tools. Because the cutting material is different, the engraving machine tool should also be installed with the corresponding tool. The engraving process is divided into two parts: roughing and finishing. Roughing is the removal of wool to obtain approximate outline features, usually with relatively large amount of cutting. The finishing stage is the process of engraving process in order to obtain the theoretical requirements of the surface. The final form and structure of the product is actually determined by the finishing stage.

When machining large size sculptures and craft products, proper displacement machines are needed to coordinate CNC machine for omnidirectional, multi angle continuous machining. In this paper, I/O conversion information is realized according to the coordinated motion principle of the positioner and the CNC machine, and the coordinate movement of the machine is controlled by the coordinate machine. The intelligent controller is the main core control element of the positioner, which coordinates the operation efficiency of the overall positioner. The intelligent controller keeps the same initial speed as the positioner, so that the intelligent controller

keeps the same running state as the positioner. The time point of the received port signal is the point at which the first instruction point begins. In particular cases, lag angles may be generated, and the angle and time can be used to determine how much the positioner is growing.

Through the preliminary design of the three-dimensional model of the new glass CNC sand blasting machine, the method of generating tool path is set up, and the theoretical research and simulation before and after the cutting process are made. The structure of CNC engraving machine and the design method of information system have been formed. It is necessary to test the CNC engraving machine to establish the consistency between the data in the simulated environment and the actual data. According to the problems of different material processing, information feedback is carried out, and a large amount of data is analyzed and summarized. After the actual stone processing in the processing system, it can verify the system's scientific validity of the new glass CNC sand blasting engraving machine designed in this paper. The basic design problems are found in the experiment, so that the optimization of the stone and glass engraving experiments will be improved in the future research work.

3. Result analysis and discussion

The structure design of the new glass CNC sand blasting engraving machine and the design scheme of the system are given in the paper. In order to verify the operation of the hardware, the test experiment of the positioner is given. The way to build the experiment is to connect the worm to the motor. The worm connects the turbine and drives the turntable. The transmission ratio of worm and turbine selected in this paper is about 50:1. The circuit is connected before the experiment, and the positioner is adjusted according to the results of the running parameters of the computer. When the performance of the worm drive reaches a stable state, the turntable is driven to rotate. After turning, the CNC machine sends out signals through I/O. The turntable motion depends on the transmission of the motor. The actual relative displacement of the robot depends on the motor encoder to feed back to the CNC machine, or after the relative error is calculated, the actual relative displacement at the next stage is calculated according to the error. The motion speed of the next stage is calculated according to the displacement, and each pulse signal can be adjusted by different stages of the relative error. The control point of the robot's tail clamp of CNC machine needs to keep consistent with the movement curve track of the machine turntable. The effect of the study is the coordinated tracking of the two.

In the experiment of the positioner, the software needs to accumulate the error of moving track continuously. The output errors of each stage are recorded through the Notepad output platform. The concept described by VR is the operation speed of CNC machine. N represents the relative cycle of motion. STEP describes the amount of movement per relative cycle. The movement speed of the displacement machine is V . The average machining cycle of CNC machine is about 20000-pulse, and other operating parameters are unchanged. If the moving speed of the glass CNC sand

blasting machine changes, the speeds are defined as 10 mm/s and 20 mm/s. The speed of the engraving machine is controlled and the relative error of motion in each cycle is obtained, as shown in Fig. 6.

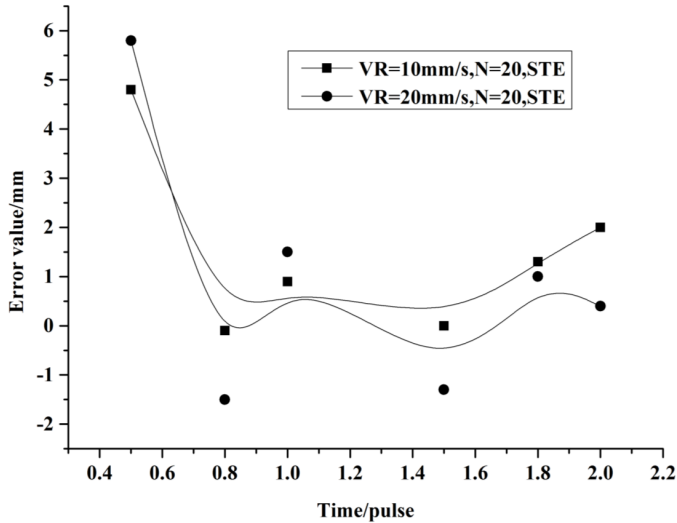

Fig. 6. The error value varies with the movement time

Through the above experimental data, it can be seen a relatively close trend of movement. In the process of starting the positioner, the error of engraving machine is relatively large. After continuous tracking adjustment, the error is gradually reduced, and finally tends to a range of changes. In the process of movement, the operation speed of CNC engraving machine needs constant adjustment, and the error value fluctuates as well. If the machine is stalled at one stage and the speed is accumulated, the next stage will run too fast and a certain rate of conflict will occur. Controller's changes will reduce the speed of operation and affect the speed of the next stage. Delays also cause errors to fluctuate within a certain range. As shown in Fig. 7, the calculated unit data show that the variance data for the first three sets are 1.26, 2.58, and 2.70, respectively, and the variance of the latter three sets is 0.22, 0.36, and 0.62, respectively. The results show that after the movement speed of CNC engraving machine is increased, the variation of the error is increased. When the exercise cycle is reduced, the trend becomes more gradual. When the movement speed of CNC engraving machine is reduced, the movement accuracy of the control position machine can be controlled by adjusting the cycle time.

4. Conclusion

According to the design and application defects of domestic stone and glass engraving equipment, a more advanced design method of new glass CNC sand blasting engraving machine was put forward in this paper. Through the CAD/CAM com-

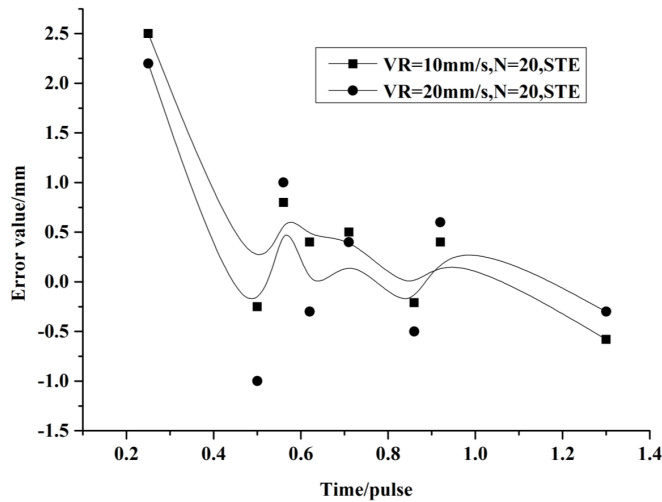

Fig. 7. The error value varies with the movement time

puter application assistance technology, the integration processing process from the three-dimensional model to the different materials was completed. The problems of small processing range and low machining accuracy of the domestic numerical control engraving machine were overcome. Referring to the basic characteristics of glass, stone and other processing processes, the overall design of the process was first designed. The design of the mechanical structure, selection, and installation process were mainly completed. In order to extend the space axis of CNC engraving machine, the hardware of the experiment was matched and the software was coordinated. The software program was programmed by C++ development platform to realize the synchronous and coordinated movement of the shifting machine and CNC engraving machine. The experimental results of the displacement machine experiment obtained in this paper can be used for the design of the large positioner with more complex structure. Combined with certain control method, the CNC sand blasting engraving machine can be designed and manufactured independently.

References

- [1] A. C. LEE, M. T. LIN, Y. R. PAN, W. Y. LIN: *The feedrate scheduling of NURBS interpolator for CNC machine tools*. Computer-Aided Design 43 (2011), No. 6, 612–628.
- [2] S. WEYER, M. SCHMITT, M. OHMER, D. GORECKY: *Towards Industry 4.0 - Standardization as the crucial challenge for highly modular, multi-vendor production systems*. IFAC-PapersOnLine 48 (2015), No. 3, 579–584.
- [3] Z. JIA, Y. CHEN, W. LIU, K. ZHAO, L. WANG, X. TU: *The control system for precise five-axis laser/micro-milling machine tool*. International Journal of Industrial and Systems Engineering 22 (2016), No. 2, paper 073960.
- [4] H. YANG, J. YAN: *DXF file identification with C# for CNC engraving machine system*. Intelligent Control and Automation 6 (2015), No. 1, 20–28.

- [5] Y. X. CHEN: *Design and development of economic type mechanical engraving machine*. Applied Mechanics and Materials 644–650 (2014), 813–816.
- [6] Z. PANDILOV, N. VESELINKOVSKI: *Improvements and benefits of upgrading CNC Machine for engraving and cleaning metal parts*. Acta Technica Corviniensis - Bulletin of Engineering 9 (2016), No. 2, 111–114.
- [7] G. M. MARTINOV, A. I. OBUHOV, L. I. MARTINOVA, A. S. GRIGORIEV: *An approach to building a specialized CNC system for laser engraving machining*. Procedia CIRP 41 (2016), 998–1003.
- [8] H. L. WU, Z. Q. ZENG, Y. Y. ZHANG: *Experiment design for crafts design and fabrication based on CNC engraving technology*. Research & Exploration in Laboratory 33 (2014), No. 12, 229–232.
- [9] X. CHEN, J. SHEN: *Numerical and experimental investigation on splitting-and-recombination micromixer with E-shape mixing units*. Microsystem Technologies 23 (2017), No. 10, 4671–4677.
- [10] Q. M. LIANG, H. J. YIN: *Modeling and simulation of the feed drive system for a type of CNC engraving and milling machine*. Mechanical Research & Application (2013), No. 2.
- [11] X. ZHANG, Y. LIU, B. GOU, L. HAN: *Design and rigidity analysis of key components in five-axis wood engraving machine*. Machine Tool & Hydraulics (2014), No. 1.
- [12] Y. LIU, C. AI, Y. YANG: *Development of motion control module for flame cutting machine CNC system*. Machine Tool & Hydraulics (2015), No. 10, paper 051.
- [13] T. A. DOW, J. NOWAK, J. R. KESSING: *Design of elliptically-vibrating ultrasonic actuator for nanocoining*. Precision Engineering 45 (2016), 301–310.

Received October 10, 2017